

SOLID STATE INTEGRATED AMPLIFIER

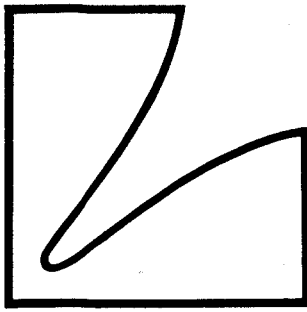

L-100

SERVICE MANUAL

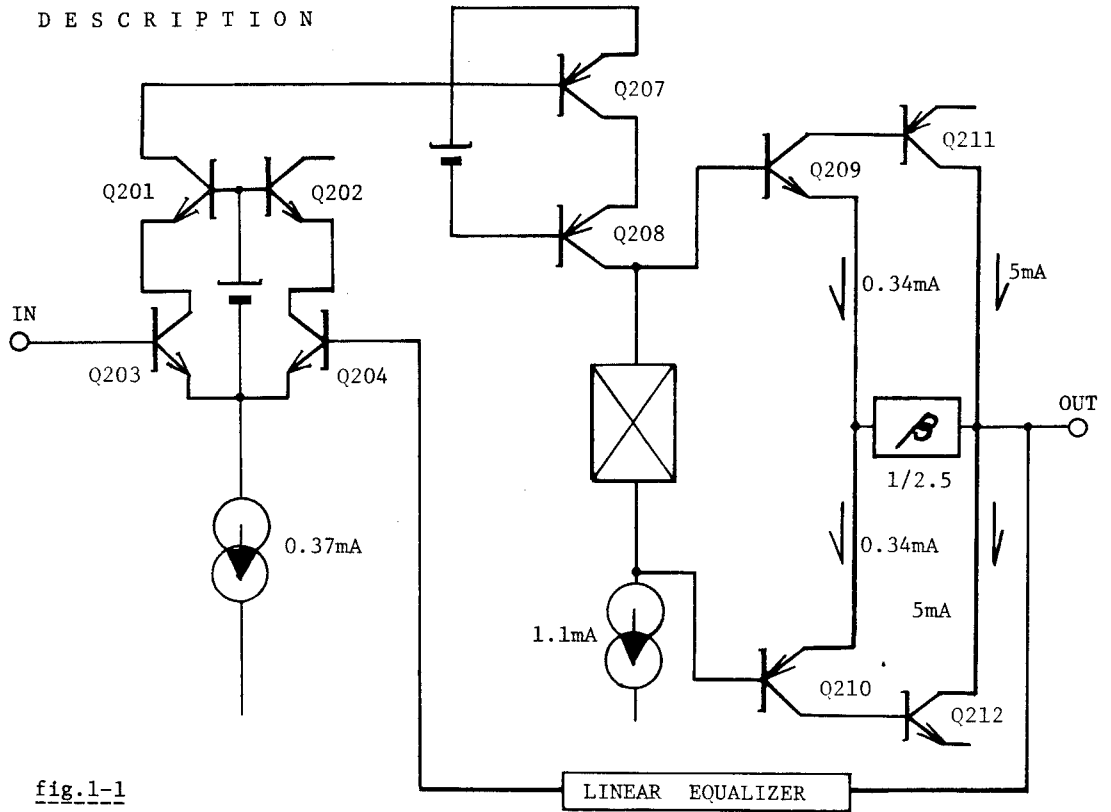

fig.1-1

1) Equalizer Stage

At the 1st stage Q203 and Q204 operate as a differential amplifier. Q201 and Q202 prevent the high frequency characteristics from deterioration, which may be caused by the change of the feedback amount originated by the fluctuation of the base-collector voltage of Q203 and Q204 in accordance with the input signals. Constant current is applied to these common emitters of Q203 and Q204 to obtain better DC stability and to increase CMRR (Common Mode Rejection Ratio).

The next stage is composed by Q207 and Q208 together with the constant current load. Q208 operates same as Q201 and Q202 at the 1st stage. The $-20V$ constant voltage driving is applied by use of a zener diode up until this stage. The Inverted Darlington configuration by Q209, Q211 and Q210, Q212 is adopted in the output stage. At the same time some 8dB gain is obtained.

A high voltage of $+43V$ is applied to ensure sufficient output voltage; maximum $27V_{r.m.s.}$. The transistors Q201 and Q208 are arranged to assist Q203 and Q202 respectively in order to operate them in the optimum condition. It is able to consider Q209 and Q211, or Q210 and Q212 to be one equivalent transistor, therefore the equivalent circuit should be as the fig.1-2.

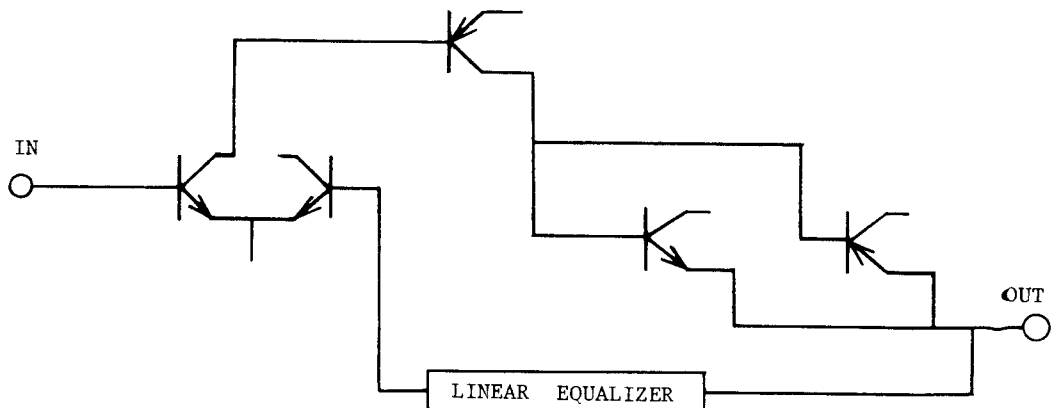

fig.1-2

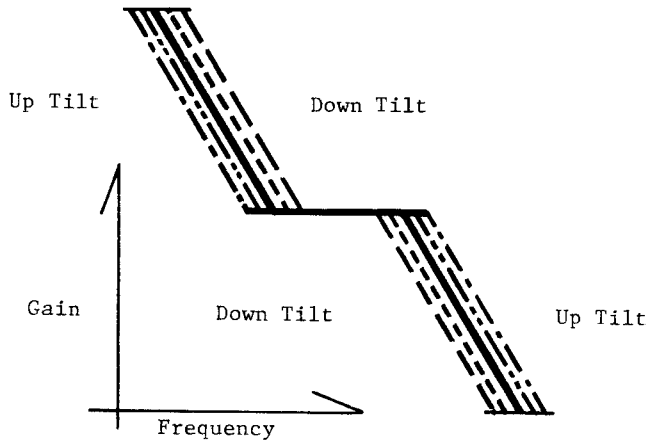
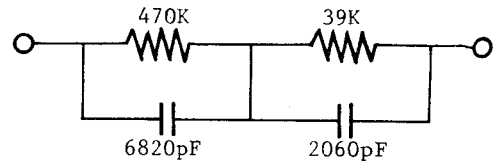

fig.1-4 Response of Linear Equalizer

The fixed values of the Linear Equalizer at its "flat" position are shown in the fig.1-3, which is the same as the R.I.A.A. elements that LUX usually adopts. The turnover frequencies are changed around the flat position to obtain the characteristic equivalent to the R.I.A.A.

2) Flat Stage

The fig.2-1 shows a circuit of a conventional flat amp., while the fig.2-2 is the one adopted in the L-100.

The deterioration in the high frequency characteristic is eliminated by adding Q3 to Q2. And further the emitter follower Q4 is arranged to assure good characteristics against various input loads.

As for the power supply $\pm 22V$ is applied. In the circuit, the low-boost circuit is incorporated. (fig. 2-3)

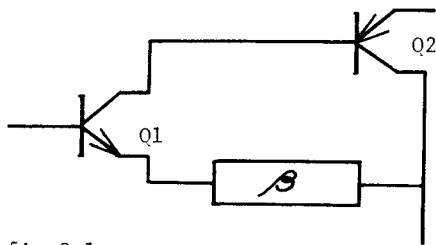

fig.2-1

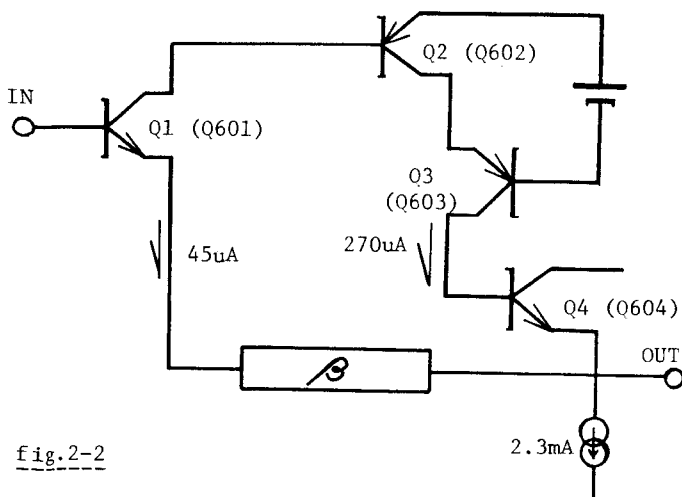

fig.2-2

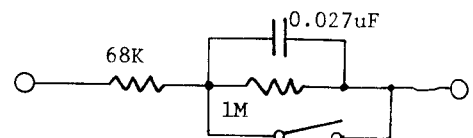

fig.2-3

3) Tone Control Stage

The fig.3-1 shows the principle of the Bass Control. In the frequency range where the impedance of C1 is negligible against V_R , the entire gain is $A_1 = \frac{R_2 + (1-k)R}{R_1 + kR}$

when $-A$ is sufficiently large. On the other hand, in the frequency range where the impedance of C1 is far low against V_R , $A_2 = \frac{R_2}{R_1}$ (fig.3-2) when the input impedance of the amplifier is large enough.

Therefore in the case of $R_1 = R_2$, it makes $A_2 = 1$ and when k is 0.5, it makes $A_1 = 1$; this flat position can be obtained. Even if it is $R_1 \neq R_2$ due to the possible aberration of employed elements, the value of k which makes $A_2 = A_1$ could be found. That is to say, the flat position can be obtained without fail.

The fig.3-3 shows the principle of the Treble Control. The R_1 and R_2 are equivalent to those in the fig.3-1 and fig.3-2. In the frequency range where the impedance of C2 is negligible, the gain is decided by the ratio of R_1 to R_2 , and when the impedance must be regarded, r_1 and r_2 begin to operate in parallel with R_1 and R_2 respectively. Suppose the parallel impedance as R_3 and R_4 , the gain is $A_3 = \frac{R_4}{R_3}$

incidentally the gain at high frequency is changed by the position of V_R .

Also at high frequency range the position that makes $R_2/R_1 = r_2/r_1$ is always obtained. And the flat position certainly exists.

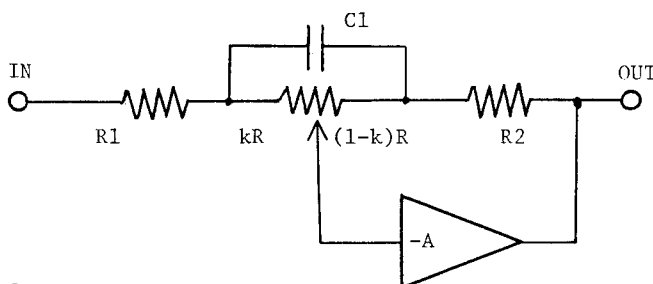

fig.3-1

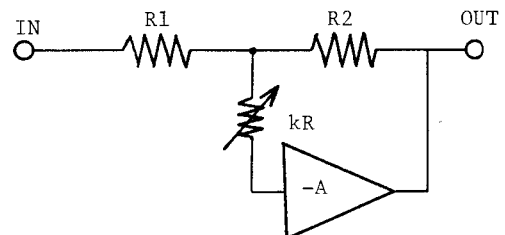

fig.3-2

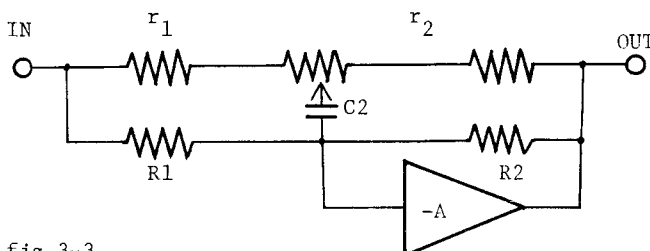

fig.3-3

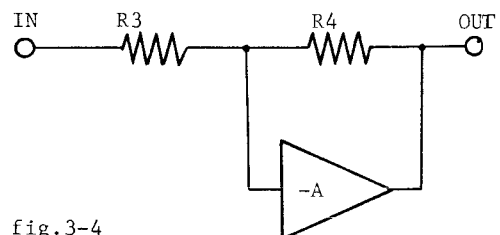

fig.3-4

As for the amplifier section, it is necessary that the gain $-A$ is sufficiently large, which might be understood by the above explanation. Also stability against the amount of the Negative Feedback should be secured since it ranges between +16dB and -16dB for the tone control characteristics.

The gain is $-A$, and incidentally an inverted amplifier is necessary. In order to obtain good stability it is important not to increase the number of amplifier stage, and therefore it should be necessary to increase the inherent gain under the said condition. The final circuit is shown in fig.3-5. The 1st stage is the differential amp utilized two different transistors, and the output is non-inverted. The 2nd stage is driven with constant current load in order to have gain sufficiently, which makes it possible to obtain the good inherent gain coupled with stabilization. The power supply is $\pm 22V$.

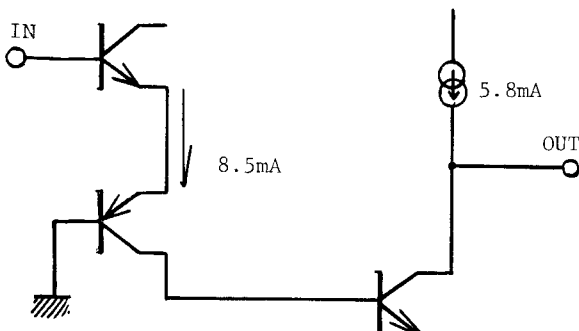

fig.3-5

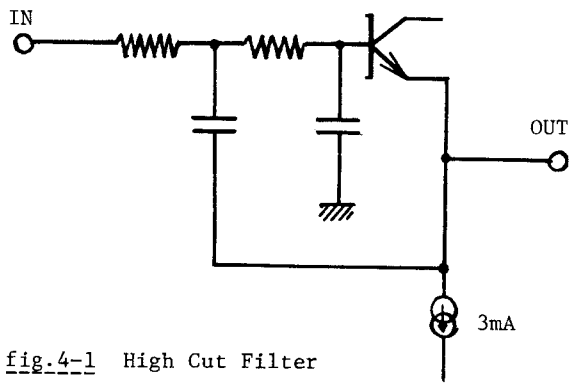

fig.4-1 High Cut Filter

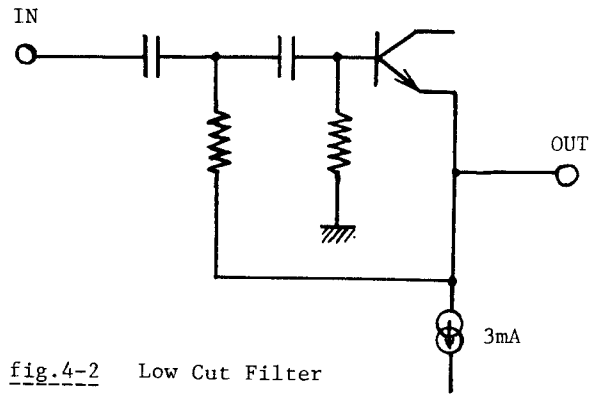

fig.4-2 Low Cut Filter

4) Filter Stage

Basically the circuit is the same with the conventional filter amps of -12dB/oct . But in order to obtain better load-characteristic, the emitter-follower circuit with constant current load is adopted.

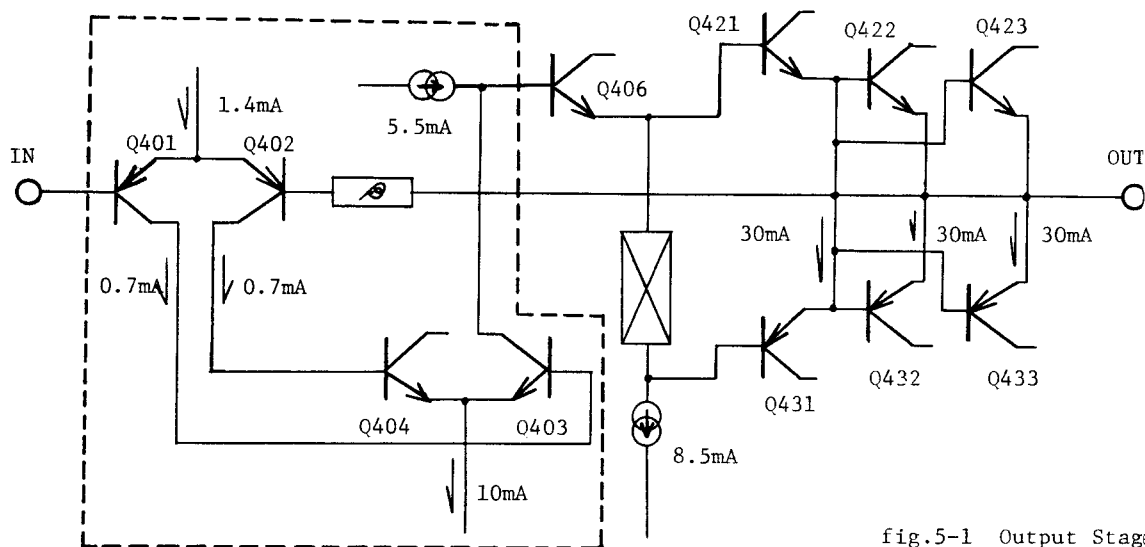

fig.5-1 Output Stage

5) Output Stage

The DC stabilization is realized by arranging 2 differential amplifier stages; the 1st one is by Q401 and Q402, while the 2nd, Q403 and Q404. Further to the circuit in dotted line, the driver stage, $+55\text{V}$ constant voltage is applied for efficient operation.

The transistors Q422 and Q423, or Q432 and Q433 are connected in parallel respectively, and are operated in the area of good linearity and comparatively small current. For Q421 and Q431, the power transistors are used and sufficient current is applied.

An emitter-follower circuit composed of Q406 for the constant current load is arranged to couple the Class "B" operational stage with the Class "A" operational stage whose power source is supplied by the constant voltage power supply. The Q406 is provided to reduce the load of Q403 and at the same time to undo the effect caused by the fluctuation of the input impedance between the Q421 and Q431.

Further, placement of Q406 better the high frequency characteristics since high frequency compensation becomes stable and therefore the margin is less necessary, and consequently it is possible to reduce the amount of compensation.

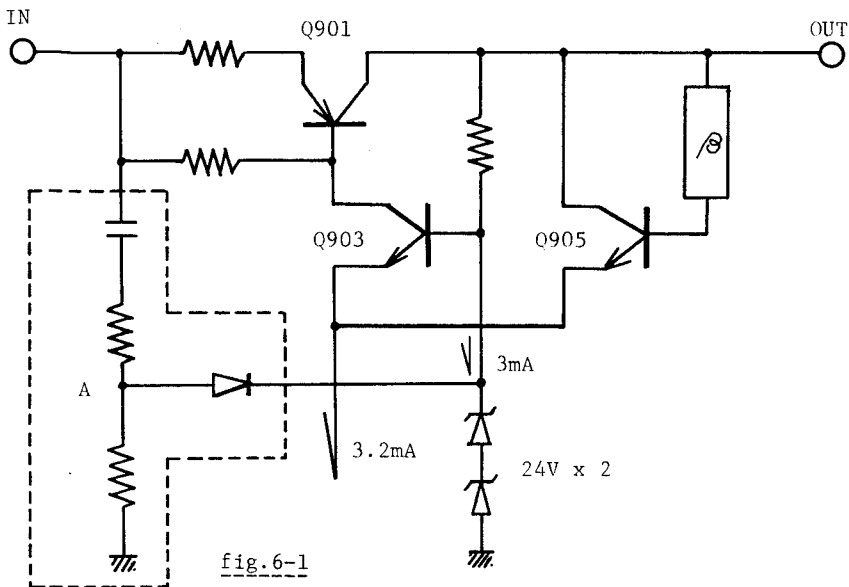

fig. 6-1

6) Power Supply Stage

Here described is (+) supply only. The basic circuit is shown in fig.6-1. The base voltage of 48V is obtained by arranging 2 zener diodes (24V) in series.

When (+) voltage is even instantly given to the output point, all the transistors Q901, Q903 and Q905 stand operative, and the stabilized power is supplied to the output point, while in case voltage is not given to the output point, those transistors are turned off, and no power source is supplied.

Thus this operates as a kind of the protection circuit.

When the voltage at the output point disappears by the short-circuit or the too heavy load, the stabilized power source is not supplied at the output point even in case the trouble is removed.

But at the same time the case that no output is available at the time of switching on of the power switch will occur.

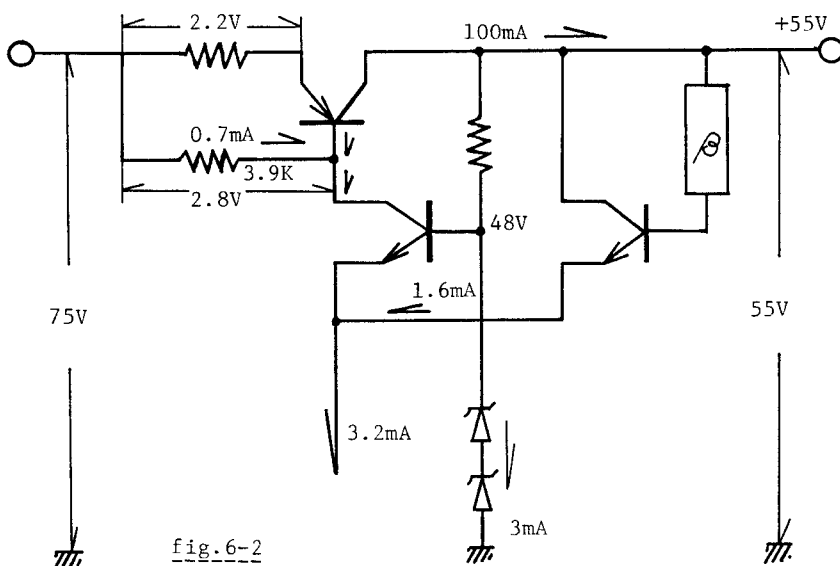

fig. 6-2

Therefore the circuit enclosed by the dotted line is quite necessary to be conditioned as per the fig.6-2 at the time of power-on. At the time of power-on the charging current flows through a capacitor, which increases potential at the point A, thus feeding trigger signal to Q903 via a diode. In the meantime charging of the capacitor is finished and the point A becomes earth potential, which makes the diode reverse-bias, thus giving no influence to the basic circuit.

However in case the increase of the power supply voltage is made gradually, the trigger signal would not be obtained, incidentally no output is available. Once this state is realized, operation is impossible until the voltage comes down by self-discharge to the level where the trigger signal is obtained. May be a half day is necessary.

For quick recovery, apply voltage enough to operate the zener diode for an instant at the output point. Practically, when (+) voltage can not be obtained, disconnect the connector on the main block, then short-circuit for an instant through 5-6K-ohm resistor any of the pins on the housing of C17M and C18M with the pin on the housing of C12M. Do the same between C13M, C14M and C11M for (-) power supply voltage. The power supply should be "on".

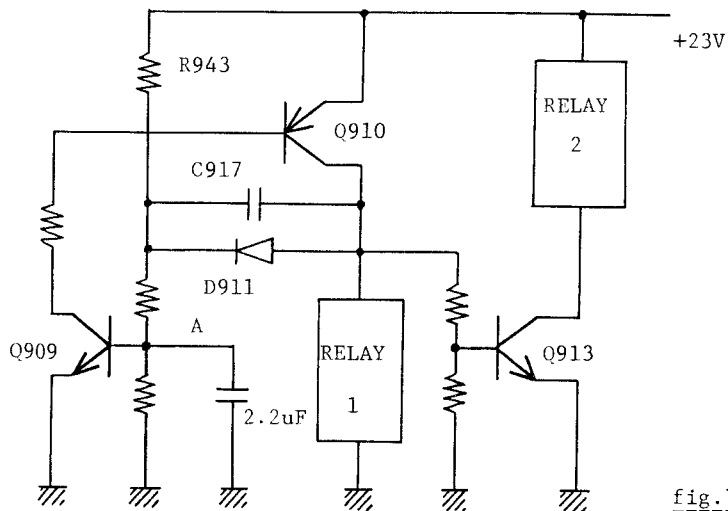

fig.7-1

7) Delay Time Muting Circuit

The power supply to this circuit is not precisely fixed to +23V but the one containing some 5V ripple. When the power supply is turned on, it rises quickly. The relay-1 for the output has some 550-ohm resistance, therefore it can be negligible against the charging

current R943 --- C917. When the sufficient voltage to operate Q909 is obtained at the point A induced by the increase of the charging potential of C917, the base current of Q910 flows to stand "on".

At this time D911 is in the forward direction and the base current of Q909 is supplied from D911. Since supplying impedance of D911 is far low than that of R943, the "ON"-state Q909 and Q910 would hardly be turned into "OFF".

Actually the range where it is guaranteed to make the relay turned "on" is in the area of 10% down of the power source, while it maintains the "ON" state until the power source is down to 30%, when for the first time the relay is turned "OFF". When the relay-1 is turned "ON", Q913 is biased to operate the pre-section of the relay-2.

In case the AC frequency is 50Hz, quantity of ripple are remain even after rectification, and especially when the ambient temperature is low, V_{be} of Q909 increases and h_{fe} decreases, therefore it is necessary to feed much current to the point A in order to turn Q909 on. But the dip point of ripple wave may possibly turn Q909 off, and that is why a 2.2uF capacitor is added to prevent this.

8) Protection Circuit

Protection is realized by suppressing the potential at the point A below 0.6V, connecting the circuit in the fig.8-1 to the point in the fig.7-1.

When (+) voltage is emerges, Q911 is turned on, while (-) voltage makes Q912 turned on. However in this state, the protection is also operated by the output voltage. Therefore a low-pass filter is provided to detect the voltage except the signal output voltage. The component values are decided so that the protection can be operated when 30Vrms appears below 20Hz into both ch driven.

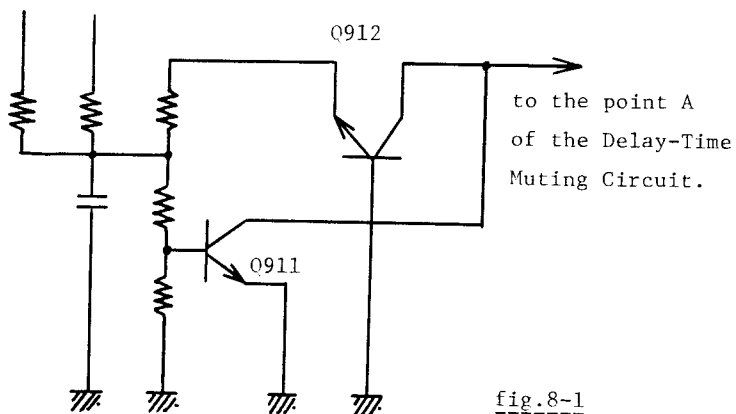

fig.8-1

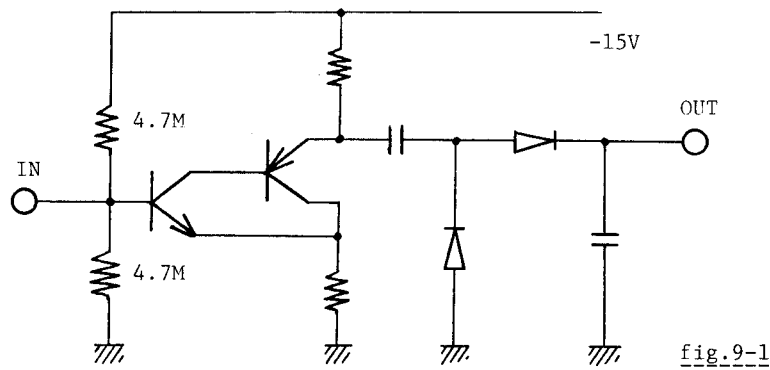

fig.9-1

9) Touch Mute Circuit

The detection circuit is common between the "ON" and "OFF". When the "IN" point is touched by fingers, hum noises appears, which is rectified in single wave in twice, when DC output appears at the "OUT" point. In case this is done, touching the chassis, hum noises are reduced, but the resistance of human body is inserted in parallel with the ground and pulses generate at (+) side, thus providing DC outputs.

But in the perfectly shielded room etc., mere touching offers too low hum level, and therefore the DC outputs may not possibly reach the necessary level. To prevent this, it is necessary to increase the gain, when DC outputs will emerge by inducing hum noises even if the "IN" point is not touched. Thus up until now it is inevitable to be miss-operated under such a special condition.

The DC output is, then, led to the retain-circuit as per the fig.8-2. The output of Touch Mute "ON" flows to Q312, then once converted to AC by capacitor, fed to D302 where picking up only (-) pulses to turn Q311 on. In case Q310 is at the "OFF" state, the output turns both Q309 and relay on, and at the same time lights up the L.E.D. display on the front panel.

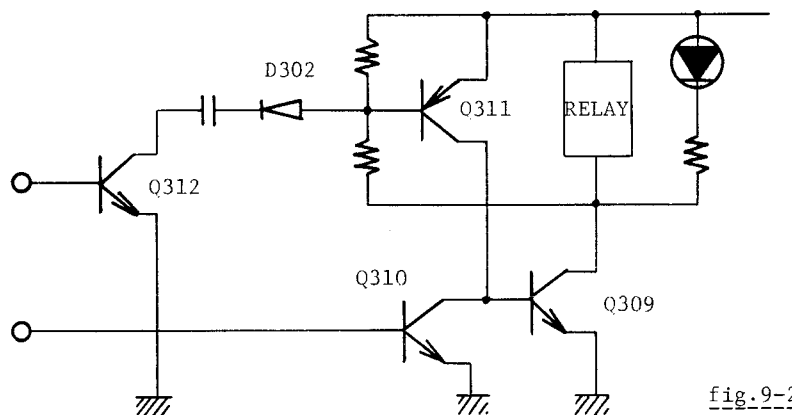

fig.9-2

The input is converted into AC-DC-AC order, and if the input is retained, it is regulated into one pulse only at the time of DC to AC conversion.

The output of "OFF" is given to Q310. When Q310 is turned on, Q309 is in the "OFF" state, and Q311 is stable in the "OFF" state unless input is given to Q312. When Q310 is in operation, even if Q312 operates and Q311 is turned on, the collector current of Q311 is absorbed by Q310, which gives no bias to the base of Q309, i.e., Q309 does not operate. But especially in case the pulse signal is given, Q309 is turned on just for an instant and is recovered to be off.

The Touch Mute Release Switch on the back panel is provided to short-circuit the base of Q312, therefore when the release switch is set at the "OFF" position at the time of Touch Mute "ON", Touch Mute "OFF" can not be realized even if the Touch Mute "OFF" button is touched; it continues "ON" function. To prevent it; operate the Touch Mute Switch to "OFF" by setting the Touch Mute Switch at the "ON" position or once turn the power switch off.

IDLE ADJUSTMENT AND ZERO OFFSET ADJUSTMENT

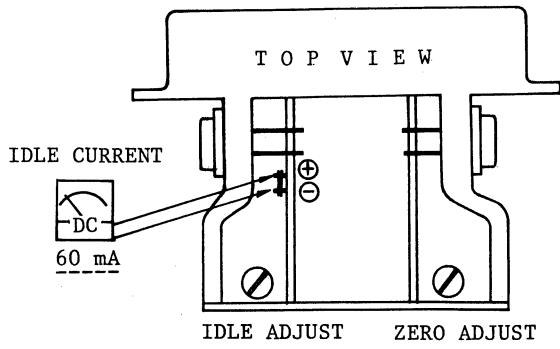

NOTICE: The final adjustment should be made after 15 minutes of stand-by operation.

MODEL: L-100

P.B. LOCATION

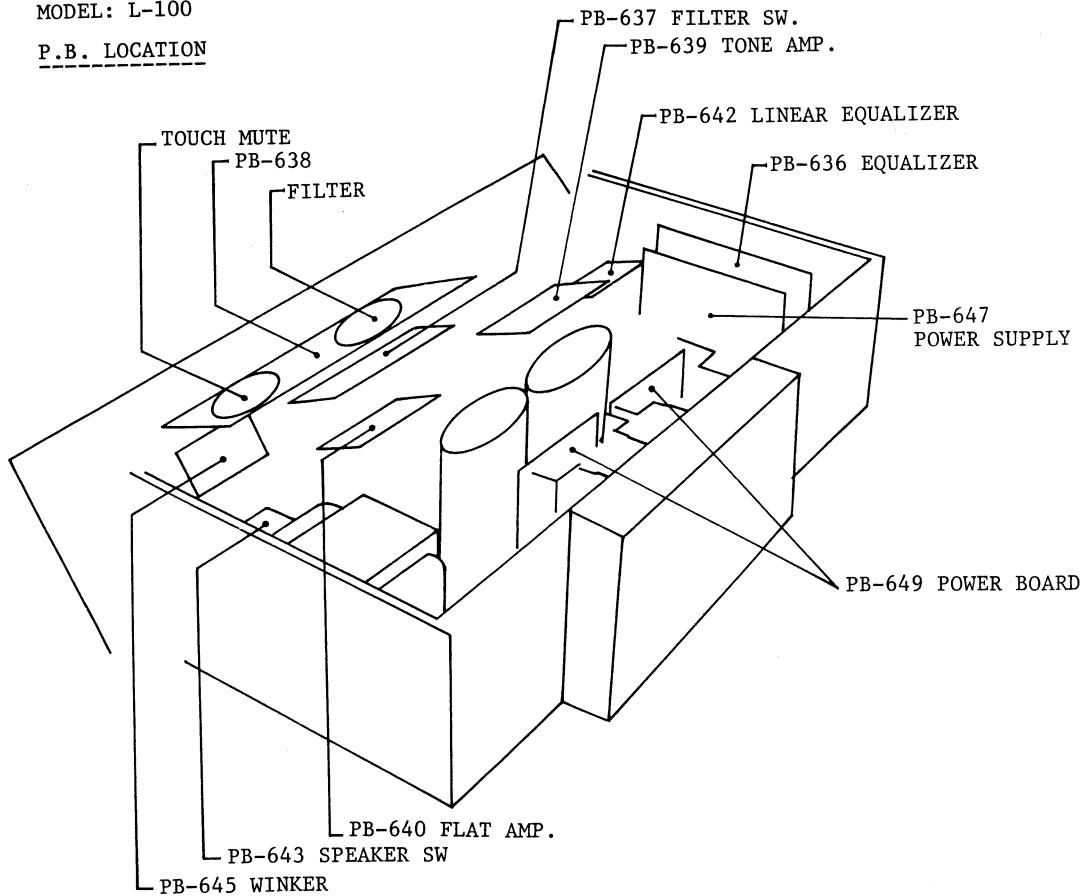

PB637

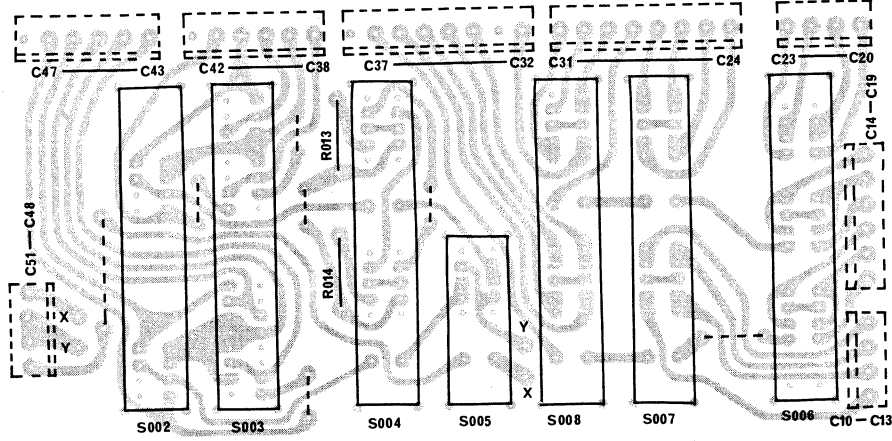

PB635

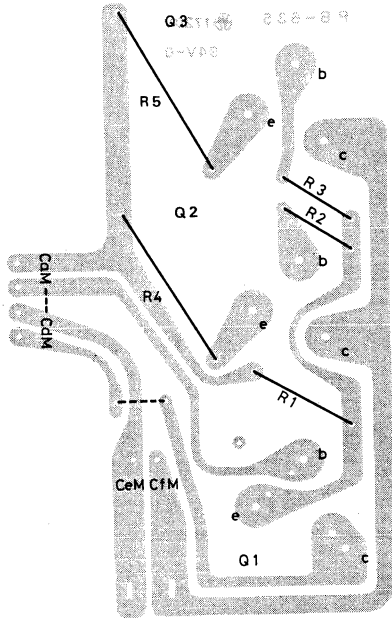

PB863 (639)

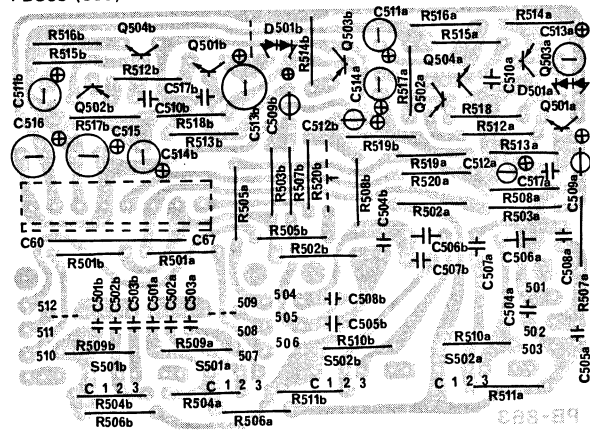

PB636

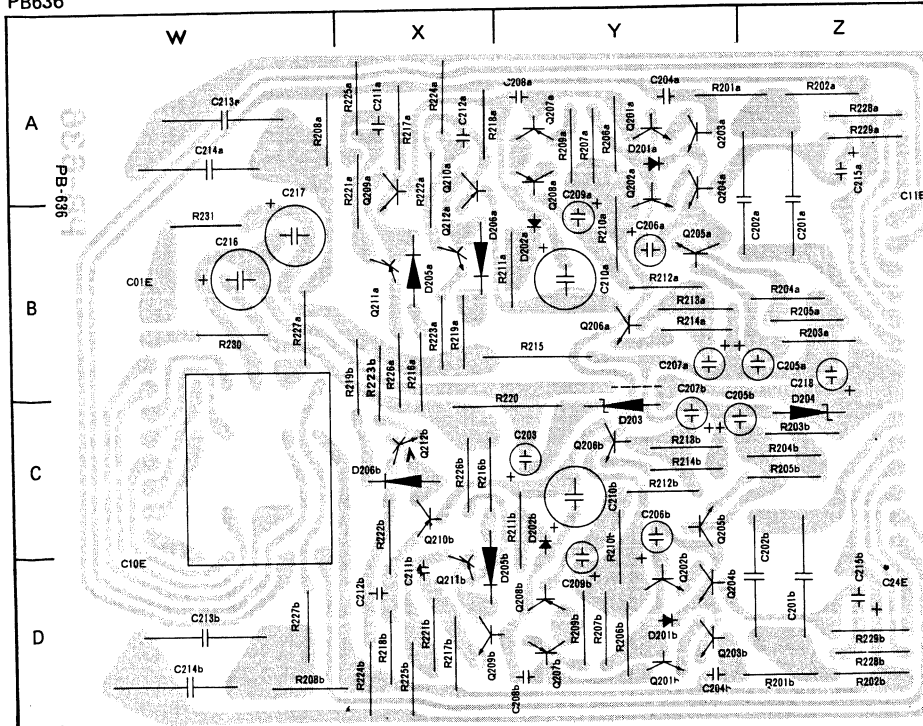

MODEL: L-100 REPLACEMENT PARTS LIST

All resistors are carbon 1/4 watt resistor unless noted otherwise. Unit of resistance is OHM.
 (Class "SG" --- low noise, Class "J" --- + 5%, Class "G" --- + 1%)

PB-642

SYMBOL NO.

R151b	510K	SG	G	AY	C153b	0.082uF	mylar	G	AY
151a	"	"	"	BY	153a	"	"	"	BY
152b	39K	"	"	AX	154b	"	"	"	AY
152a	"	"	"	BX	154a	"	"	"	BY
153b	1.0M	"	J	AY	155b	"	"	"	AY
153a	"	"	"	BY	155a	"	"	"	BY
154b	"	"	"	AY	156b	0.0015uF	"	"	AX
154a	"	"	"	BY	156a	"	"	"	BX
155b	"	"	"	AY	157b	0.0012uF	"	J	AX
155a	"	"	"	BY	157a	"	"	"	BX
156b	"	"	"	AY	158b	820pF	styrol	J	AX
156a	"	"	"	BY	158a	"	"	"	BX
157b	1.5M	"	J	AX	159b	560pF	"	"	AX
157a	"	"	"	BX	159a	"	"	"	BX
158b	"	"	"	AX	160b	270pF	"	"	AX
158a	"	"	"	BX	160a	"	"	"	BX
159b	"	"	"	AX	S151ab, S152ab		FP-245		AX, BX
159a	"	"	"	BX	110	59BS8806	terminal		AY
160b	"	"	"	AX	111	"	"		AY
160a	"	"	"	BX	112	"	"		BY
C151b	8200pF	mylar	G	AY	113	"	"		BY
151a	0.0082uF	"	G	BY					
152b	0.082uF	"	"	AY					
152a	"	"	"	BY					

PB-640

SYMBOL NO.

R601a	470K	SG	J	AY	VR601	250K1Z2Z50KohmBB			CX, CY
601b	"	"	"	BY	C601a	4.7uF	10V	tantalum	BY
602a	1K	"	"	BY	601b	"	"	"	BY
602b	"	"	"	BY	602a	33pF	50V	ceramic	AX
603a	150K	SG	"	AX	602b	"	"	"	BX
603b	"	SG	"	BX	603a	4.7uF	25V	tantalum	AY
604a	100	"	J	AX	603b	"	"	"	BY
604b	100	"	J	BX	604a	47uF	10V	electrolytic	AI
605a	1.5K	"	J	AX	604b	"	"	"	BY
605b	"	"	J	BX	605a	0.027uF		mylar	AY
606a	470K	SG	J	AX	605b	"		"	BY
606b	"	SG	J	BX	606a	47uF	10V	electrolytic	AI
607a	47K	"	J	AX	606b	"	"	"	BI
607b	47K	"	J	BX	607	47uF	25V	"	AI
608a	1.2K	"	J	AX	608	"	"	"	AI
608b	1.2K	"	J	BX	Q601a	2SC1345		E	AI
609a	2.2K	"	J	AY	601b	"		"	BI
609b	"	"	J	BY	602a	2SA640		F	AI
610a	F-180	"	J	AX	602b	"		"	BI
610b	"	"	J	BX	603a	"		"	AI
611a	270	"	J	AY	603b	2SA640		F	BI
611b	"	"	J	BY	604a	2SC1345		E	AI
612a	270K	"	J	AY	604b	"		"	BI
612b	"	"	J	BY	605a	"		"	AI
613a	150K	"	J	AY	605b	"		"	BI
613b	"	"	J	BY	C01F - C10F	5004-10A			BY
614a	12K	"	J	AY	C11F - C16F	5004-6A			CI
614b	"	"	J	BY	C17F - C22F	5004-6A			CI
615a	68K	"	J	AY	P617	SJT-701	terminal		AI
615b	"	"	J	BY	618	"	"		AI
616a	1.0M	"	J	AY	620	"	"		AI
616b	"	"	J	BY					
617a	1.8K	"	J	CY					
617b	"	"	J	CY					
618a	5.6K	"	J	CY					
618b	"	"	J	CY					

PB-637

S002	SLA32353
003	SLA34352
004	SLA34302
005	SLA32311
006	SLA36303
007	SLA34302
008	SLA34302
R013	6.8Kohm J
014	6.8Kohm J

PB-643

R019	700-ohm	5W	K
020	700-ohm	5W	K
S0009ab	2F-0002DF2110		
51 - 58	SJT-701		

PB-645

R701	33-ohm		J
703	1M		J
704	1K		J
705	18K		J
706	1M		J
707	33		J
708	6.8K		J
C701	22uF	16V	electrolytic
702	22uF	16V	electrolytic
703	470uF	16V	electrolytic
D701	IS1554		
702	22Kohm	J	
703	IS1554		
704	IS1554		
Q701	2SC945		
702	2SC945		
LM701	NO3010	Bi-Pin	
LM702	NO3010	Bi-Pin	
Q01	2SA620-WLH	W5	BZ
02	2SA620-WLH	W5	AZ
03	2SC1507		AZ
04	2SC1507		AZ
05	2SB536	L	AY
06	2SC1507		AY
07	2SD381	L	BY
08	2SC734		AX
(reverse-side 0.1uF 12V ceramic BX)			

PB-635

R1	22-ohm	1W	J	flame-proof
2	10		J	"
3	10		J	"
4	0.33	5W		cement
5	0.33	5W		cement

NOTE: On the circuit diagram these symbol numbers are described as, for instance, R421, R431, R821, R831, which is also applied to R2 - R5 since there are 4 same PCB's.

Q1	2SC1079Y	for Q421, Q821
	2SA679Y	for Q431, Q531
Q2,Q3	2SD287BQR	for Q422, 423, 822, 823
	2SB539BQR	for Q432, 433, 832, 833

PB-649

NOTE: Symbol No. here are equivalent to the figure on the circuit diagram, for instance R401 or R801, R402 or R802 etc. Resistors are 1/4 watt Class J unless otherwise noted.

R01	4.7K		BZ
02	100K		BZ
03	1.2K		BZ
04	39K		AZ
05	3.3K		BZ
06	3.3K		AZ
07	180	flame-proof	AZ
08	180	flame-proof	AZ
09	220		AZ
10	120		AY, AZ
11	82		BY, AY
12	47K	1/2W	AY
13	2.7K		AX, AY
14	47		AY, BY
15	220		BX
16	220		BX
17	33K	1/2W	BX
18	33K	1/2W	BX
19	8.2	1W	AX, AY
VR01	1Kohm	B	AX
02	4.7Kohm	B	BX
C01	1.2uF	250V metalized film	BZ
02	100pF	K ceramic	BY
03	330uF	6.3V electrolytic	BY
04	470uF	6.3V electrolytic	BZ
05	33pF	K 500V ceramic	AZ
06	100pF	K ceramic	AY
07	220pF	ceramic	AZ
08	10pF	K 500V ceramic	BZ
09	470uF	6.3V electrolytic	AX
10	0.1uF	M ceramic	AX
11	0.1uF	M ceramic	BX
12	2.2uF	100V electrolytic	AX
13	2.2uF	100V electrolytic	BX
14	2.2uF	100V electrolytic	AY
15	2.2uF	100V electrolytic	BY
16	2.2uF	100V electrolytic	BX
17	2.2uF	100V electrolytic	BX
D01	VD1221		AZ
02	VD1221		AY
03	SV-03		AY

PB-647

R901	22-ohm	1W	AW	R918	2.2K	AZ	R935	33	BY,CY
902	22	1W	AY	919	330	1W	936	1.0K	CY
903	3.9K		AW	920	330	1W	937	22K	CY
904	3.9K		AZ	921	22		938	4.7K	CY
905	22K		BW	922	22		939	18K	CX
906	22K		BZ	923	33		940	18K	CX
907	22K		BW	924	100		941	1.0K	CX
908	22K		BZ, AZ	925	68		942	1.0K	CY
909	15K		AW	926	68		943	47	CY
910	15K		AZ	927	100		944	4.7K	BY,AY
911	4.7K		AW	928	33		945	1.0K	BY,AY
912	4.7K		AZ	929	10 1/2W	AX,BX			
913	18K		AW	930	10 1/2W	AX			
914	18K		AZ	931	10 1/2W	AX			
915	12K		BW	932	10 1/2W	AX			
916	12K		AZ	933	560 1/2W	CY			
917	2.2K		AW	934	330K	BY			
C901	33uF	100V	electrolytic	CY,CZ	C911	100uF	25V	electrolytic	CW
902	33uF	100V	electrolytic	BY,BZ	912	100uF	25V	electrolytic	CZ
903	2.2uF	100V	electrolytic	AW	913	0.068uF	K	mylar	AX
904	2.2uF	100V	electrolytic	AZ	914	0.068uF	K	mylar	AW
905	100pF	K	ceramic	AW	915	330uF	10V	electrolytic	BY
906	100pF	K	ceramic	AZ	916	47uF	50V	electrolytic	CZ,CY
907	150pF	K	ceramic	BW	917	100uF	25V	" NP	BY,CY
908	150pF	K	ceramic	CZ	918	100uF	25V	" NP	CX,CY
909	47uF	25V	electrolytic	BW	919	0.068uF	K	mylar	BX
910	47uF	25V	electrolytic	BZ					
VR901	4.7Kohm	B	AW	Q901	2SA653	Q	AW		
902	4.7Kohm	B	AZ	902	2SC1161	Q	AZ		
				903	2SC945	P	AW		
D901	W04		AY	904	2SA733	P	AZ		
902	IN4003		AY	905	2SC945	P	AW		
903	IN4003		AY	906	2SA733	P	AZ		
904	IS1554		BY	907	2SD382	L	BW		
905	IS1554		BW	908	2SB537	L	CZ		
906	IS1554		AZ	909	2SC945	P	CY		
907	WZ-240		BW	910	2SA562	Y	CY		
908	WZ-240		BZ	911	2SC945	D	CY		
909	WZ-240		CW	912	2SC945	D	CY		
910	WZ-240		BZ	913	2SC735	Y	AY		
911	IS1554		CY	L901	LUX1004-2MH	BX			
912	IN4003		BY	902	LUX1004-2MH	BX			
Relay	MAT 2B-CR		CX						

PB-636

R201a	470		AZ	R212a	39K	SG	BY	R223a	82	BX
201b	470		DZ	212b	39K	SG	CY	223b	82	CX,BX
202a	560K	SG	AZ	213a	1.5K		BY,BZ	225a	82	AX
202b	560K	SG	DZ	213b	1.5K		CY,CZ	225b	82	DX
203a	39K	SG	BZ	214a	820		BY,BZ	226a	82	CX,BX
203b	39K	SG	CZ	214b	820		CY,CZ	226b	82	CX
204a	3.3K		BZ	215	2.7K	1/2W	BY	227a	270	BW
204b	3.3K		CZ	220	2.7K	1/2W	BY	227b	270	DW
205a	2.7K	SG	BZ	216a	1.2K	flame	prf BX	228a	470	AZ
205b	2.7K	SG	CZ	216b	1.2K	"	CX	228b	470	DZ
206a	4.7K	SG	AY	217a	1.8K		AX	229a	1.0K	AZ
206b	4.7K	SG	DY	217b	1.8K		DX	229b		DZ
207a	330K	SG	AY	218a	1.8K		AX	230	10	BW
207b	330K	SG	DY	218b	1.8K		DX	231	10	BW
208a	100K		AW	219a	1.2K	flame	prf BX			
208b	100K		DW	219b	1.2K	"	BX			
209a	10		AY	224a	82		AX			
209b	10		DY	224b	82		DX			
210a	1.5K		BY	221a	2.7K		AX,BX			
210b	1.5K		DY,CY	221b	2.7K		DX			
211a	820		BY	222a	2.7K		AX,BX			
211b	820		CY	222b	2.7K		CX,DX			

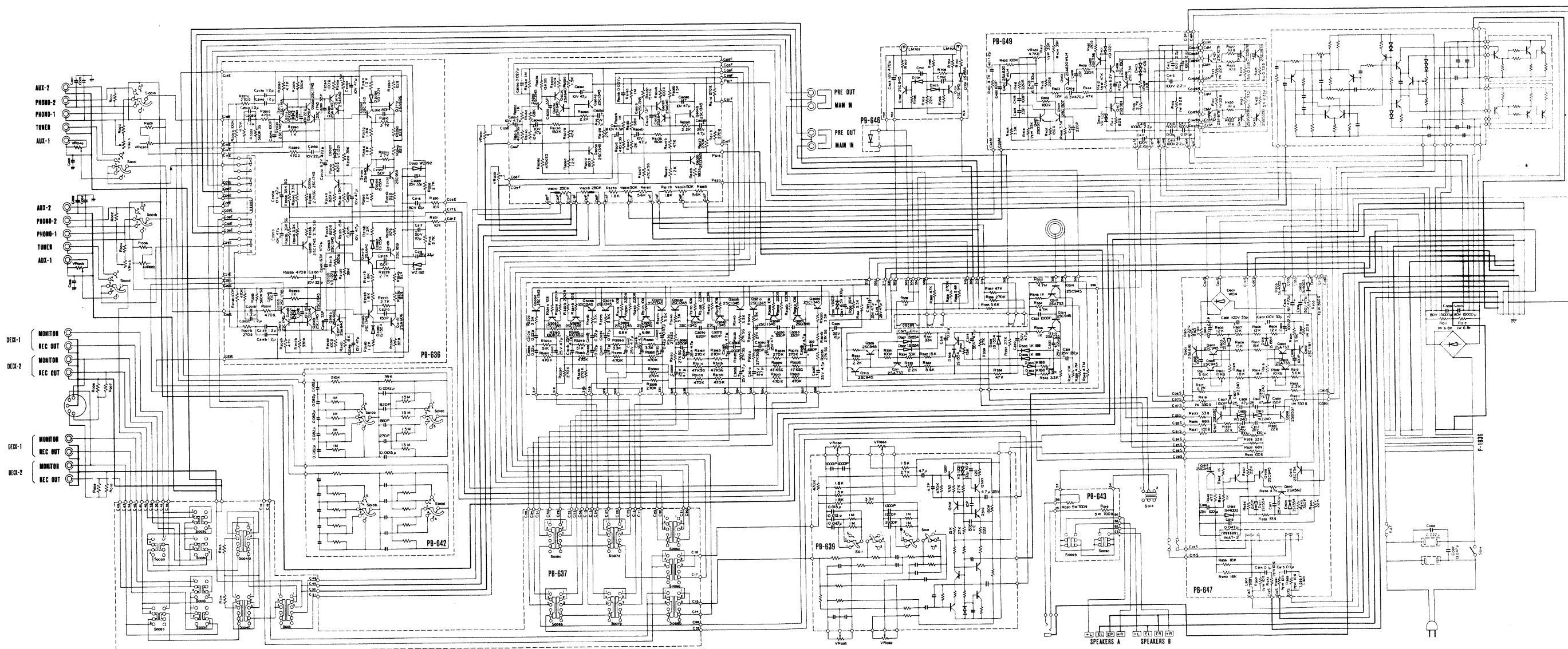

S1a1bcd FUNCTION (1.AUX-1 2.TUNER 3.PHONO-1 4.PHONO-2 5.AUX-2)
 S2a1b MONITOR (1.DECK-1 2.SOURCE 3.DECK-2)
 S3a1bcd DUBBING (1.DECK-1 TO DECK-2 2.SOURCE 3.DECK TO DECK-1)
 S4a1b MODE (1.REVERSE 2.STEREO 3.MONO)
 S5a1 MODE (1.LEFT 2.STEREO 3.RIGHT)

S6a1bc TONE CONTROL (1.TONE CONT & LOW BOOST 2.OFF TONE CONT)
 S7a1b LOW CUT FILTER (1.70Hz 2.OFF 3.10Hz)
 S8a1b HIGH CUT FILTER (1.7KHz 2.OFF 3.12KHz)
 S9a1b SPEAKERS (a.SPEAKERS B b.SPEAKERS A)
 S10a1bcd LINER EQUALIZER (1.2.UP TILT 3.FLAT 4.5.DOWN TILT)

S11 BASS (1.150Hz 2.300Hz 3.600Hz)
 S12 TREBLE (1.1.5KHz 2.3KHz 3.6KHz)
 S13 TOUCH MUTE OFF
 S14 POWER

VR1a1b PHONO-1 IN PUT IMPEDANCE SET
 VR2a1b PHONO SENSITIVITY SET
 VR3a1b VOLUME CONTROL CONTROL
 VR4a1b TUNER INPUT LEVEL SET
 VR5a1b BASS CONTROL

VR6a1b TREBLE CONTROL
 VR7a1b BALANCE CONTROL
 VR8a1c ATTENUATOR

NOTICE : BOLD LINES ARE GROUND(ONE-POINT EARTH)

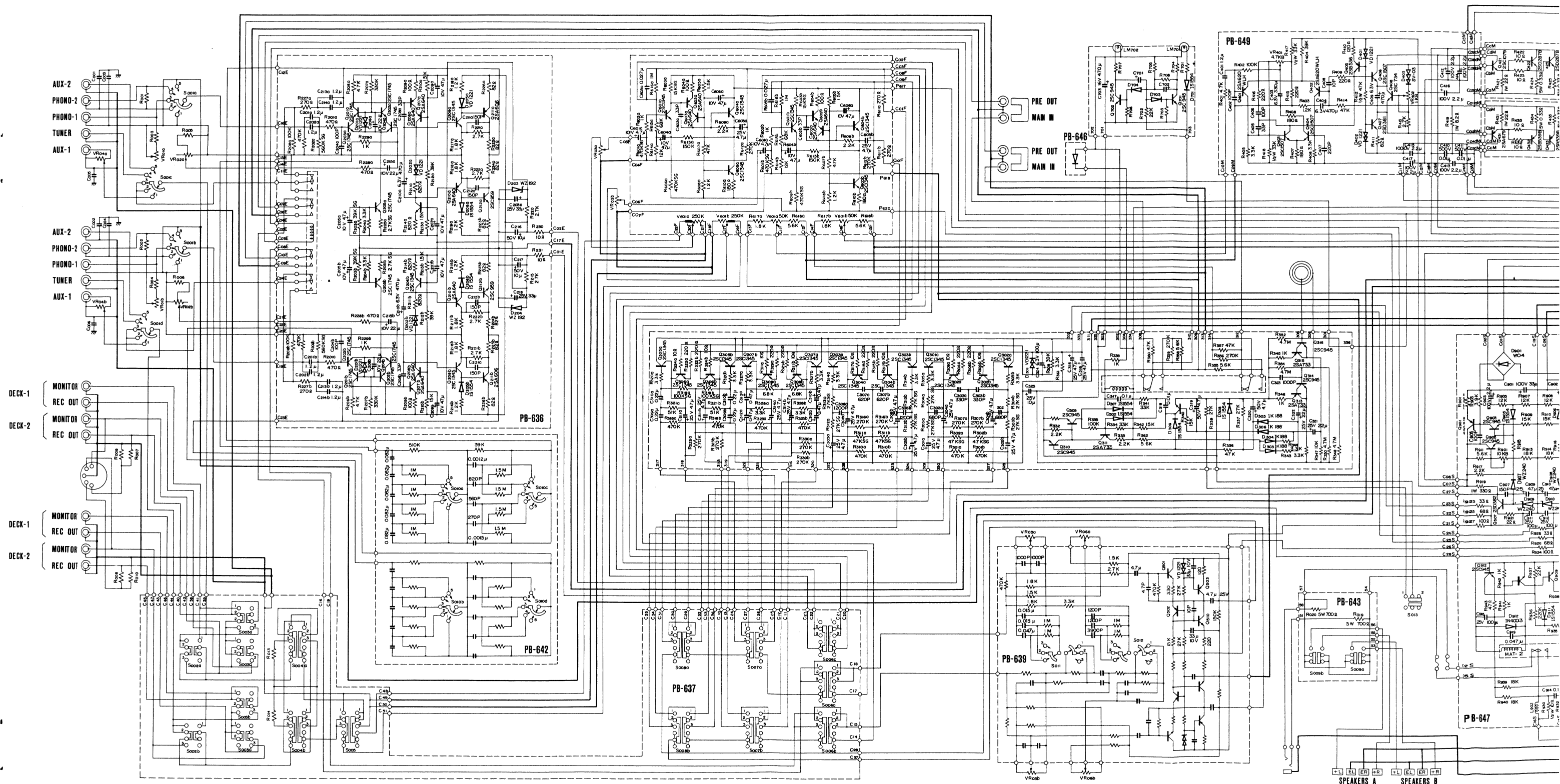

- S001a,b,c,d FUNCTION (1.AUX-1 2.TUNER 3.PHONO-1 4.PHONO-2 5.AUX-2)
- S002a,b MONITOR (1.DECK-1 2.SOURCE 3.DECK-2)
- S003a,b,c,d DUBBINGS (1.DECK-1 TO DECK-2 2.SOURCE 3.DECK TO DECK-1)
- S004a,b MODE (1.REVERSE 2.STEREO 3.MONO)
- S005 MODE (1.LEFT 2.STEREO 3.RIGHT)

- S006a,b,c TONE CONTROL (1.TONE CONT & LOW BOOST 2.OFF TONE CONT)
- S007a,b LOW COT FILTER (1.70KHz 2.OFF 3.10KHz)
- S008a,b HIGH COT FILTER (1.7KHz 2.OFF 3.12KHz)
- S009a,b SPEAKERS (a.SPEAKERS B b.SPEAKERS A)
- S010a,b,c,d LINER EQUALIZER (1.2.UP TILT 3.FLAT 4.5.DOWN TILT)

- S011 BASS (1.150Hz 2.300Hz 3.600Hz)
- S012 TREBLE (1.1.5KHz 2.3KHz 3.6KHz)
- S013 TOUCH MUTE OFF
- S014 POWER

- VR01a,b PHONO-1 IN PUT IMPEADANCE SET
- VR02a,b PHONO SENSITIVITY SET
- VR03a,b VOLUME CONTROL CONTROL
- VR04a,b TUNER INPUT LEVEL SET
- VR05a,b BASS CONTROL

- VR06a,b TREBLE CONTROL
- VR001a,b BALANCE CONTROL
- VR001c,d ATTENUATOR

NOTICE : BOLD LINES ARE GROUND(ONE-POINT EARTH)

SPEAKERS A SPEAKERS B

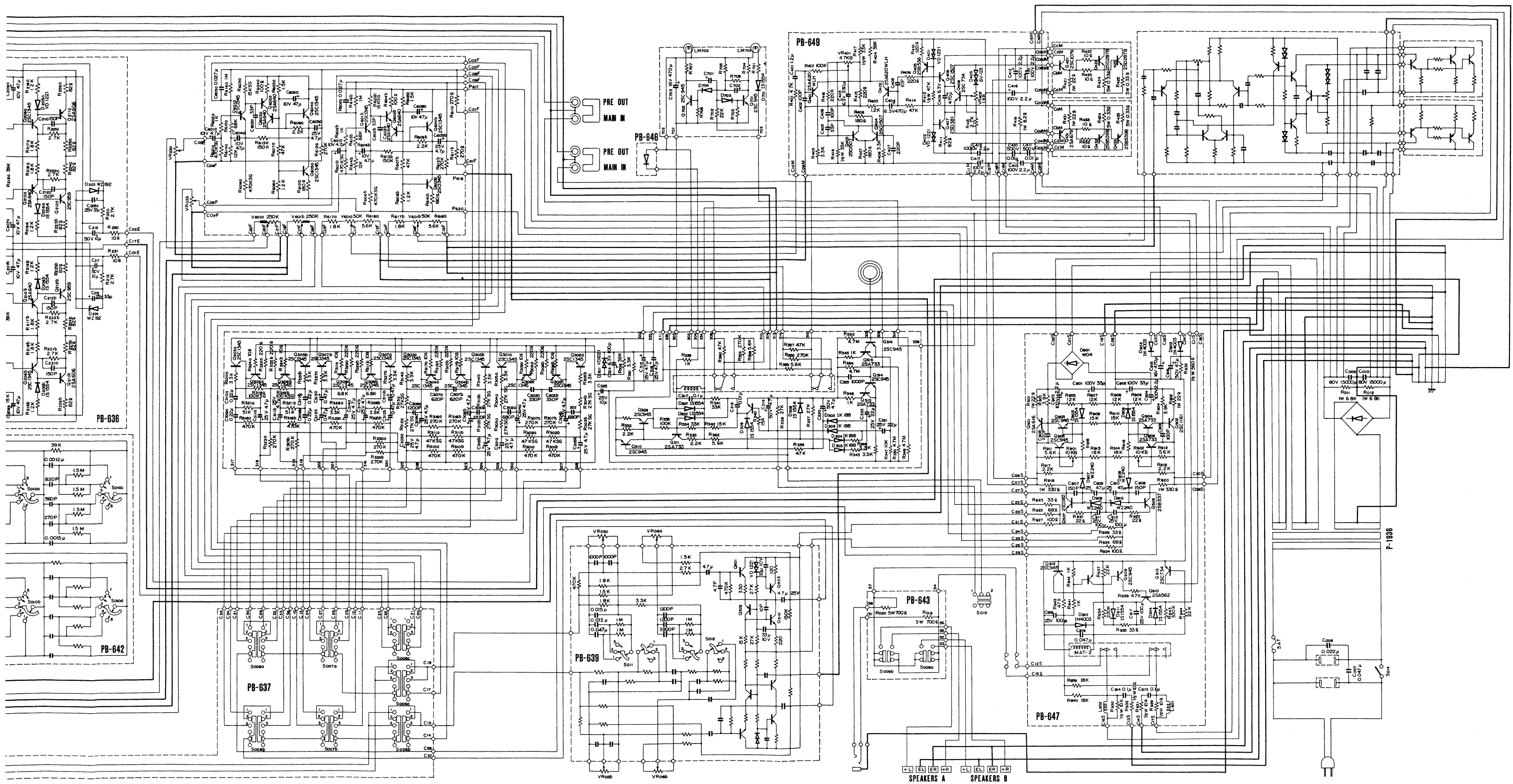

- | | | | | | | |
|---------------------------------|------|---------------------------------|---------|-------------------------------|---------|-----------------|
| NT & LOW BOOST 2.OFF TONE CONT) | S011 | BASS (1.150Hz 2.300Hz 3.600Hz) | VR01a,b | PHONO-1 IN PUT IMPEADANCE SET | VR08a,b | TREBLE CONTROL |
| 2.OFF 3.10Hz) | S012 | TREBLE (1.1.5KHz 2.2KHz 3.6KHz) | VR02a,b | PHONO SENSITIVITY SET | VR09a,b | BALANCE CONTROL |
| 2.OFF 3.12KHz) | S013 | TOUCH MUTE OFF | VR03a,b | VOLUME CONTROL CONTROL | VR01c,d | ATTENUATOR |
| b.SPEAKERS A) | S014 | POWER | VR04a,b | TUNER INPUT LEVEL SET | | |
| FILT 3.FLAT 4.5.DOWN TIL) | | | VR05a,b | BASS CONTROL | | |

NOTICE : BOLD LINES ARE GROUND(ONE-POINT EARTH)

BLOCK DIAGRAM

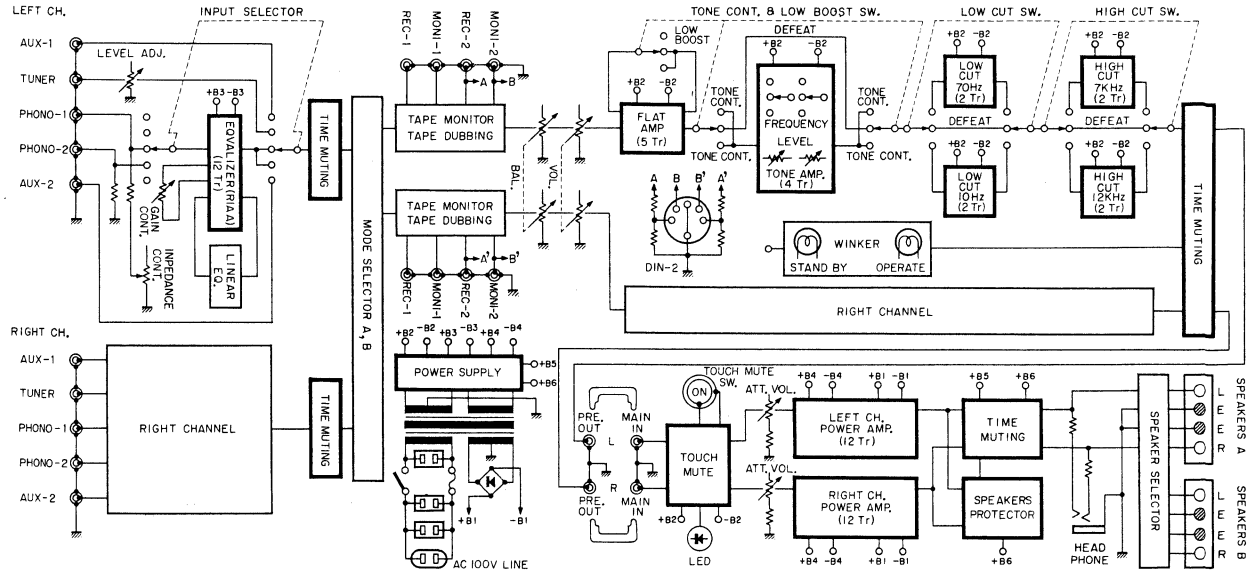

LUX CORPORATION, JAPAN

HEAD OFFICE & FACTORY 1-8-31 NAGAHASHI, NISHINARI-KU, OSAKA
 PHONES: 632 0031 CABLE: LUXELECT OSAKA
 TELEX: J63694

LUX AUDIO OF AMERICA LTD.

200 AERIAL WAY, SYOSSET, NEW YORK 11791, U.S.A.
 PHONE: (516)822-7070